

FINAL REPORT OF INVESTIGATION A&I E18476

October 31, 2018
Collision with object

W-0022

Adopted by the Washington Metrorail Safety Commission at its meeting on February 13, 2020.

Washington Metrorail Safety Commission
777 North Capitol Street, NE, Suite 402
Washington, DC 20002



FINAL REPORT OF INVESTIGATION A&I E18476

SMS 20181031#75410

Date of Event:	October 31, 2018
Type of Event:	Collision with an Object
Incident Time:	04:39 hrs.
Location:	National Airport (C10) C2 364+50
Time and How received by SAFE:	04:57 hrs., SAFE On Call Phone
Safety Officer Response:	Yes
Time of Safety Officer Arrival:	06:15 hrs.
Time of Safety Officer Departure:	07:30 hrs.
Rail Vehicle:	ID 408, 3126 -27x3088-89x3059-58x3019-18
Injuries:	None
Damage:	Yes
Emergency Responders:	TRST, SAFE

Executive Summary

On October 31, 2018, at approximately 04:39 hrs., Rail Operations Control Center (ROCC) reported Employee Train ID 408, Lead Car 3126's collector shoes were being knocked off due to contact with an old piece of running rail at National Airport (C10) Chain Marker CM C364+50 Track 2. No other damage or injuries were reported as a result of this incident.

Further investigation revealed that no collector shoes were knocked off. When Train ID 408 entered the station, a collector shoe on car 3126 made contact with the old rail, resulting in the collector shoe fuses to blow on the left side of the car, disabling the train. Train ID 408 was taken out of service for further inspection by Car Engineering (CENV) and Car Maintenance (CMNT).

Based on the salient facts, SAFE has concluded that the RWIC did not perform a thorough track inspection of the work area at the completion of his task. The old rails were staged in the track bed, however, the rails fouled the dynamic envelope of Train ID 408, therefore, when the train came into the station, the collector shoes came in contact with the rail. This contact caused the train to blow the Collector Shoe fuses and to break off a Collector Shoe Paddle, preventing it to move to its destination resulting in a delay of revenue service

Notification

Title	Time	Comment:
FTA	06:57 hrs.	WMSC Notification

Incident Site

National Airport (C10) C2 364+50

Field Sketch/Schematics

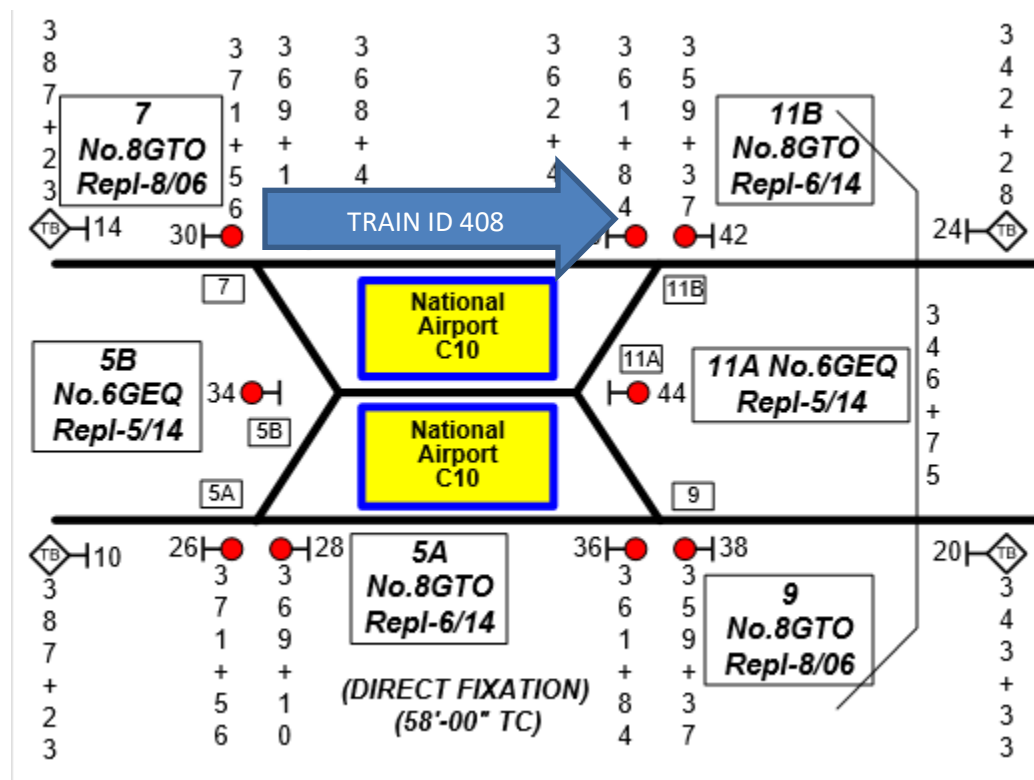

Investigation

On October 31, 2018, at approximately 04:39 hrs., Train ID 408 (Employee Train), Lead Car 3126's collector shoes made contact with an old piece of running rail that was stored on the non-third rail side of C10 platform Track 2, CM C2 364+50. Track and Structure (TRST) personnel were installing rail stringers in the platform area on an early out outage from Braddock Road (C12) to C10 Track 2. Personnel placed the old rails between the running rail and platform area, however, the platform was supported with screw jacks that prevented one of the rails to safely store next to the others causing it to sit high. According to an interview with the Roadway Worker In Charge (RWIC), he felt it was out

of the dynamic envelope of any train movement. Nevertheless, when Train ID 408 entered the station, a collector shoe on car 3126 made contact with the old rail, resulting in the collector shoe fuses to blow on the left side of the car, disabling the train. Further investigation revealed that no collector shoes were knocked off. Train ID 408 was taken out of service for further inspection. No additional damages or injuries were reported.

Weather

At the time of the incident, the temperature was 47°F, and clear. SAFE has concluded that weather was not a contributing factor in this incident (Weather source: National Oceanic Atmospheric Administration (NOAA) - Location: Washington, DC.)

Findings

- Train ID 408 was the morning's employee train
- TRST was replacing rails within the platform area at C10, Track 2
- Old rails were stored between the running rail and platform area
- One of the stored rails was sitting higher than the others
- When Train ID 408 entered C10 the collector shoes of car 3126, bridged the old unsecured rail
- When the collector shoe made contact with the old rail, it blew the collector Shoe Fuses on the left side of car 3126
- Train 408 operator reported the train was losing power and the Evaporator was inoperable.
- Train 408 Operator was instructed to cut trucks on car numbers 3089-3088-3059-3058 and verify the green brake indicator lights.
- Train 408 Operator reported trucks were cut and the green brake indicator lights were verified on car numbers 3059 and 3058.
- Car Maintenance (CMNT) Mechanics were dispatched to replace the collector shoe fuses to enable Train ID 408 to move
- The train was taken out of service for further inspection
- The impeding rail was removed and stored at a safe location.

Immediate Mitigation

1. Train Consist was removed from service
2. TRST cut the old rail and removed it to a secure area
3. The RWIC was counseled and re-trained in the proper inspection procedures of the work area at the end of the shift.

Conclusion

Based on the salient facts, SAFE has concluded that the RWIC did not perform a thorough track inspection of the work area at the completion of his task. The old rails were staged

in the track bed, however, the rails fouled the dynamic envelope of Train ID 408, therefore, when the train came into the station, the collector shoes came into contact with the rail. This contact caused the train to blow the Collector Shoe fuses and to break off a Collector Shoe Paddle, preventing it to move to its destination resulting in a delay of revenue service.

Considering all the facts gathered from this investigation, SAFE is recommending the closure of E18476.

Corrective Action

The RWIC was counseled and re-trained in the proper procedures to perform a proper track inspection of the work area at the end of his nightly assignment.

Attachments



**Washington Metropolitan Area Transit Authority
Maintenance and Material Management System
Work Order Details**

Work Order #: 14624493
Type: CM



Status: CLOSE
11/03/2018 14:07

Work Description: TRAIN ID#408 COLLECTOR SHOE CAME IN CONTACT WITH AN OLD RUNNING RAIL AT C10-C2-364 + 00 DISABLING TRAIN, 0/0, C10, PWR, SHOE, 408

Job Plan Description:

3019/18 X 3059/58 X 3088/89 X 3127/26 SHOE FUSES BLOWN ON LEFT SIDE..

Work Information

Asset: R3126	3126, RAIL CAR, BREDA, 3000 AC, A CAR	Owning Office: CMNT-CMNT-CMNT	Parent:
Asset Tag: R3126		Maintenance Office: CMNT-WFCH-INSP	Create Date: 10/31/2018 09:03
Asset S/N: 3126		Labor Group:	Actual Start: 10/31/2018 09:07
Location: 2494	K99, WEST FALLS CHURCH YARD	Crew:	Actual Comp: 10/31/2018 22:39
Work Location: 1437	E99, GREENBELT YARD	Lead:	Item: L18050002
Failure Class: CMNT009	PRIMARY POWER	GL Account: WMATA-02-33370-50499160-041-*****-OPR**	Target Start:
Problem Code: 2494	NO PRIMARY POWER	Supervisor: [REDACTED]	Target Comp:
Requested By:		Requestor Phone: [REDACTED]	Scheduled Start:
Chain Mark Start:		Chain Mark End:	
Create-Mileage: 2276122.0		Complete-Mileage: 2276122.0	

Task IDs

Task ID	Description	Component	Work Accomplished	Reason	Status	Position	Warranty?
10	INSTALLED COLLECTOR SHOE 2 FUSES AND 1 COLLECTOR SHOES, OPS CHECKS GOOD.	000-300-H00 SUBSYSTEM; PRIMARY POWER	INSTALLED	FOREIGN OBJECT DAMAGE	CLOSE		N
20	PERFORMED UNDER CAR INSPECTION PERFORMED UNDER CAR INSPECTION OF DAMAGED VEHICLE, RAIL-CARS 3126-27, 3018-19, 3088-89. INVOLVED IN INCIDENT REQUIRING COLLECTOR SHOE FUSE REPLACED AND COLLECTOR SHOES ADJUSTED TO SPEC WITH PROPER TOOL. 17 TO 22 FT POUNDS.	000-300 RAIL CAR	CHECKED	INCIDENT//ACCIDENT	CLOSE	UNDSIDE	N

Planned Materials

Task ID	Item	Description	Storeroom	Issue Unit	Quantity	Unit Cost	Line Cost
	R18350018	FUSE:COLLECTOR SHOE	200	EA	2		
Total Planned Materials:							

Actual Labor

Task ID	Labor	Start Date	End Date	Start Time	End Time	Approved?	Regular Hours	Premium Hours	Line Cost
10	[REDACTED]	10/31/2018	10/31/2018	20:20	22:30	Y	02:10	00:00	
10	[REDACTED]	10/31/2018	10/31/2018	20:20	22:30	Y	02:10	00:00	
10	[REDACTED]	10/31/2018	10/31/2018	20:20	22:30	Y	02:10	00:00	
10	[REDACTED]	10/31/2018	10/31/2018	20:20	22:30	Y	02:10	00:00	
20	[REDACTED]	10/31/2018	10/31/2018	21:00	21:30	Y	00:30	00:00	

WT_plust_woprint.rptdesign

03/25/2019 13:44

Attachment 1 – WO for Train Car 3126, page 1 of 2



Washington Metropolitan Area Transit Authority
Maintenance and Material Management System
Work Order Details

Work Order #: 14624493
Type: CM



Status: CLOSE
11/03/2018 14:07

Work Description: TRAIN ID#408 COLLECTOR SHOE CAME IN CONTACT WITH AN OLD RUNNING RAIL AT C10-C2-364 + 00 DISABLING TRAIN, 0/0, C10, PWR, SHOE, 408

Job Plan Description:

Actual Labor									
Task ID	Labor	Start Date	End Date	Start Time	End Time	Approved?	Regular Hours	Premium Hours	Line Cost
Total Actual Hour/Labor:							09:10	00:00	
Actual Materials									
Task ID	Item	Assetnum	Description	Storeroom	Trans Date	Issue Unit	Quantity	Unit Cost	Line Cost
	R18350018		FUSE:COLLECTOR SHOE	200	10/31/2018	EA	2		
Total Actual Materials:									
Related Incidents									
Ticket	Description	Class	Status	Relationship					
8368410	TRAIN ID#408 COLLECTOR SHOE CAME IN CONTACT WITH AN OLD RUNNING RAIL AT C10-C2-364 + 00 DISABLING TRAIN, 0/0, C10, PWR, SHOE, 408	SR	PENDING	ORIGINATOR					
Failure Reporting									
Cause	Remedy	Supervisor	Remark	Date					
1929	FOREIGN OBJECT DAMAGE	2825 REPAIRED		10/31/2018					
Remarks: VERIFIED FAILURE, INSTALLED COLLECTOR SHOE FUSES (2) AND COLLECTOR SHOES (1), C/W UNDER CAR INSPECTION, NO DAMAGES FOUND.									

Attachment 1 - WO for Train Car 3126, page 2 of 2

Photos



Photo 1 – Old rail that made contact with the collector shoe



Photo 2 – Old rail was cut and moved